

DSB[®]

OWNER'S MANUAL
MANUAL DE USUARIO

PSW10.4D

10" DUAL VOICE COIL
SHALLOW SUBWOOFER

SUBWOOFER PLANO DE 10"
DE DOBLE BOBINA

4+4 Ω

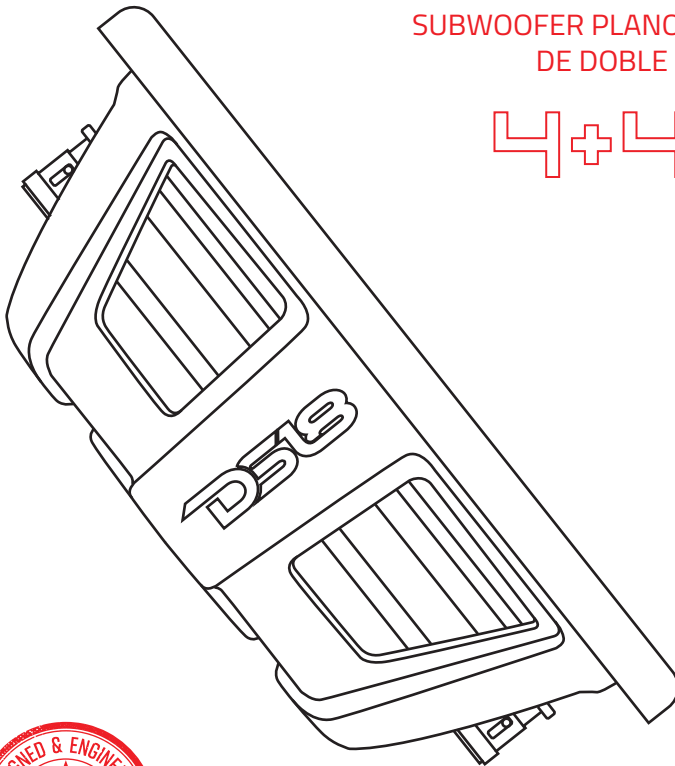

ENGLISH | ESPAÑOL



SPECIFICATIONS / ESPECIFICACIONES:

Nominal Diameter / Diámetro Nominal	10" / 254 mm
Nominal Impedance / Impedancia Nominal	4+4 OHMS
RMS Power Handling / Manejo de Potencia RMS	500 Watts
MAX Power Handling / Manejo de Potencia MAX	1000 Watts
Sensitivity (1w/1m) / Sensibilidad (1w / 1m)	84 dB
Frequency Response / Respuesta de Frecuencia	20-800 Hz
Recommended Lo Pass Crossover / Corte Paso Bajo Recomendado.....	90 Hz

MOTOR / MOTOR:

Voice Coil Diameter / Diámetro de la Bobina de Voz.....	2.5" / 63.5 mm
VC Former Material / Material Interior de Bobina de Voz.....	Aluminum / Aluminio
Winding Material / Material del Embobinado	Copper / Cobre
Cone Material / Material del Cono	Water Resistant PPI / PPI Resistente al Agua
Surround Material / Material de la Suspensión	Rubber / Caucho
Basket Material / Material de la Canasta.....	Steel / Acero
Basket Color / Color de la Canasta.....	Matte Black / Negro Mate
Magnet Material / Material del Imán	Ferrite / Ferrita
Magnet Weight / Peso del Imán	58 Oz
Displacement Volume / Volumen de Desplazamiento	0.8 L / 0.028 ft3

THIELE & SMALL PARAMETERS / PARÁMETROS T/S:

Equivalent Volume / Volumen Equivalente	Vas.....	25.6 L / 0.9 ft3
Excursion (one way) / Excursión (1 vía).....	Xmax	9.5 mm
Free Air Resonance / Resonancia al Aire Libre	Fs	32 Hz
Mechanical Factor / Factor Mecánico	Qms	3.612
Electrical Factor / Factor Eléctrico	Qes	0.76
Total Factor / Factor Total	Qts	0.63
Moving Mass / Masa en Movimiento	Mms	154 g
Compliance / Cumplimiento Mecánico.....	Cms	0.161 mm/N
BI Factor / Factor BI	BI.....	8.57
Voice Coil Inductance / Inductancia de Bobina de Voz.....	Le	2.1 mH
Diaphragm Area / Área del Diafragma	Sd.....	336.54 cm ²
DC Resistance / Resistencia DC	Re.....	3.6 + 3.6 OHMS
Efficiency Bandwidth Product / Eficiencia del Ancho de Banda del Producto	EBP.....	42

RECOMMENDED ENCLOSURE / CAJA RECOMENDADA:

Sealed Internal Volume (minimum) / Volumen Interno Sellado (mínimo)	14.2 L / 0.5 ft3
Sealed Box Output Response (F3) / Respuesta de salida de Caja Sellada (F3)	44 Hz

MEASUREMENT / MEDIDAS:

Overall Diameter/ Diámetro Total	10.23" / 260 mm
Overall Depth/ Profundidad Total	3.6" / 92 mm
Front Mount Baffle Cutout / Corte del Orificio de Montaje.....	9.2" / 234 mm
Mounting Depth / Profundidad de Montaje	3" / 78 mm
Motor Diameter/ Diámetro del Motor	6.5" / 165 mm

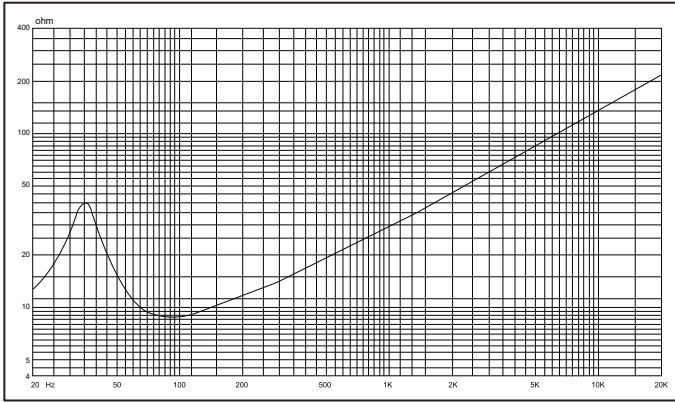

MEASUREMENTS / MEDIDAS:

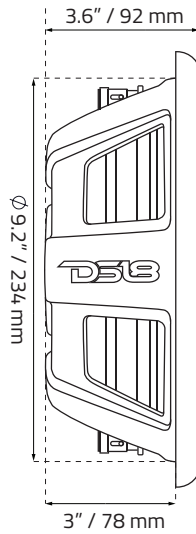
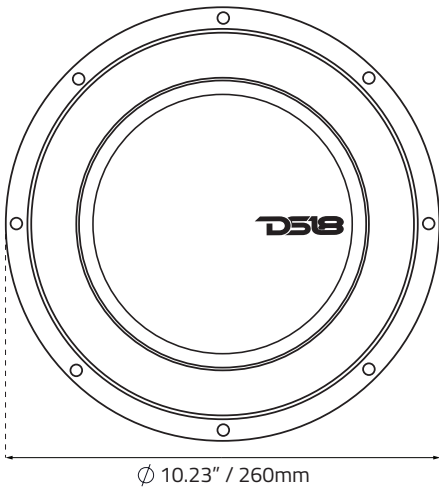

WARRANTY

Please visit our website DS18.com for more information on our warranty policy.

We reserve the right to change products and specifications at any time without notice. Images may or may not include optional equipment.

GARANTÍA

Visita nuestra página web DS18.com para obtener más información sobre nuestra garantía.

Nos reservamos el derecho de cambiar productos y especificaciones en cualquier momento sin previo aviso. Las imágenes pueden incluir o no equipo opcional.



WARNING:

Cancer and Reproductive Harm.
www.P65Warning.ca.gov



ADVERTENCIA:

Cáncer y Daño Reproductivo.
www.P65Warning.ca.gov

Recommended Box Dimension / Dimensiones de Caja Recomendadas:

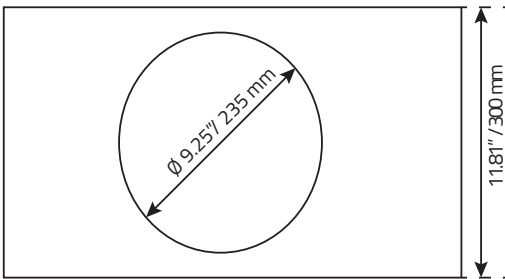

PARAMETERS / PARÁMETROS:

- **Box External Dimensions**
Dimensiones Externas de la Caja
(WxHxD): 21.65" x 11.81" x 5.41" /
550 mm x 300 mm x 137.5 mm
- **Material Thickness:** 1/2" / 15 mm
Grueso del Material
- **Net Internal Volume:** 14.2L / 0.5ft³
Volumen Interno Neto

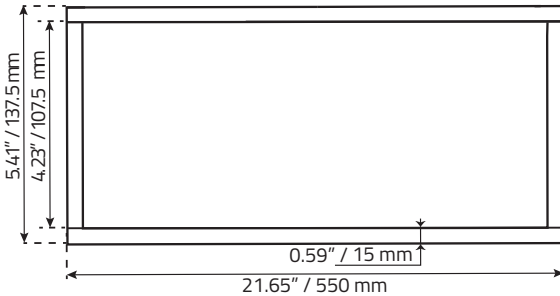

WOOD CUTS / CORTES DE LA MADERA: QTY

- **Top - Bottom / Arriba-Abajo**
(WxH): 21.65" x 5.41" / 550 x 137.5 mm 2
- **Front - Rear / Frente - Atras:**
(WxH): 21.65" x 10.63" / 550 x 270 mm 2
- **Left - Right / Izquierdo-Derecho:**
(WxH): 4.23" x 10.63" / 107.5 x 270 mm 2

WE LIKE IT LOUD

FOR MORE INFORMATION PLEASE VISIT
DS18.COM

DS18®