

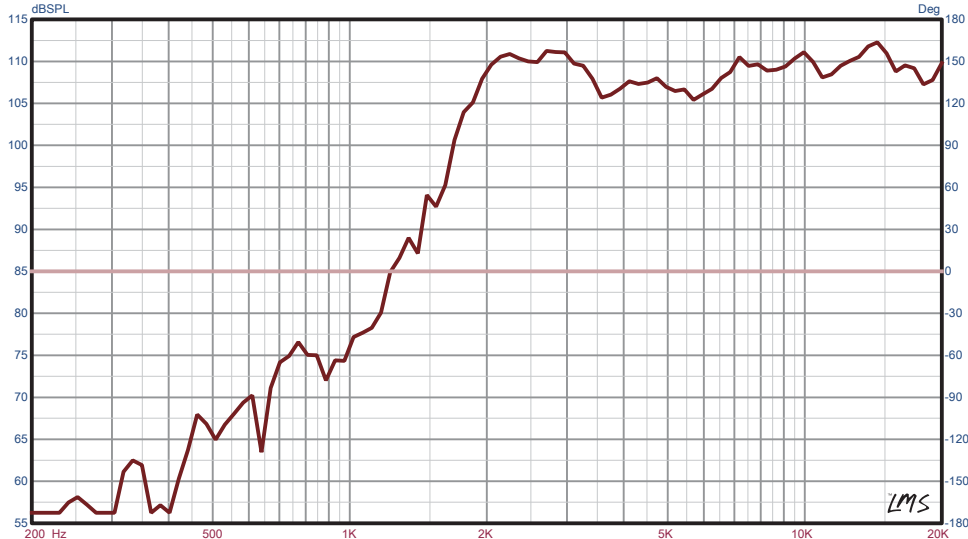

PRO-TWN2

1" Super Tweeter with Bullet  
Nominal Impedance: 4 ohms  
RMS Power Handling: 100 Watts  
MAX Power Handling: 200 Watts  
Sensitivity (1W/1M): 107 dB  
Frequency Range: 1KHz - 20 KHz  
Diaphragm Material: Composite Polyimide  
Voice Coil Diameter: 1" / 25.4 mm  
Frame Material: Die Cast Aluminum  
Magnet Material: Neodymium

SPL vs Freq



PRO-TWN2

1" SUPER TWEETER WITH BULLET

OWNER'S MANUAL



#WELIKEITLOUD    

DS18.COM



# PRO-TWN2

1" SUPER TWEETER WITH BULLET

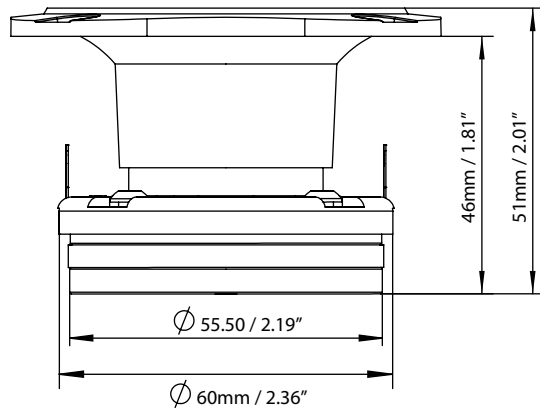
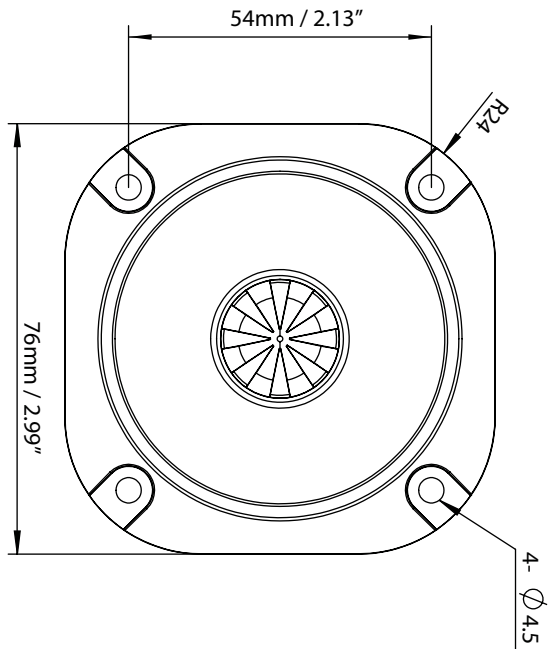

## Data Sheet

PRO-TWN2 1" SUPER TWEETER WITH BULLET

### Specifications

Nominal Impedance	4 ohms
RMS Power Handling	100 Watts
MAX Power Handling	200 Watts
Sensitivity (1w/1m)	107 dB
Frequency Response	1 K-20 KHz
Recommended Hi Pass Crossover	2 KHz
Voice Coil Diameter	1" (25.4 mm)
Winding Material	CCAW
Diaphragm Material	Composite Polyimide
Frame Material	Aluminum
Basket Material	Aluminum
Magnet Material	Neodymium

### Measurements

Overall Depth	2.01" (51 mm)
Mounting Depth	1.81 (46 mm)
Overall Width	2.99" (76 mm)
Cutout Diameter	2.36" (60 mm)

### Shipping Info

Gross Single Unit Weight	0.35 Kg
Single Unit Box Dimensions	W x L x H 8.4 x 8.4 x 7.3 cm
Quantity of Units in Master Carton	12 PCS / CTN
Gross Master Carton Weight	5.3 KG
Master Carton Dimensions	W x L x H 27 x 18x 14.5 cm

#WELIKEITLOUD    

DS18.COM