

# INSTALLATION MANUAL:

**COR-4110010**

Jeep Gladiator Rear Lower Control Arm Bracket Skid Plate  
(2020+, JT)

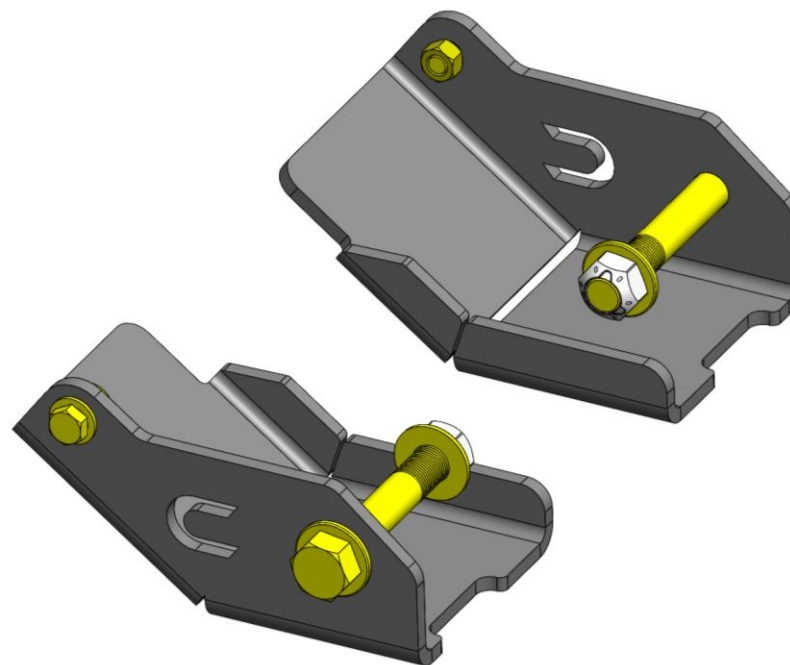

# INCLUDED ITEMS

4110010 Jeep Gladiator Rear Lower Control Arm Skid Plate (2020+, JT)			
QTY	Part Number	Description	Class/Grade
2	4110010	Jeep Gladiator Rear Control Arm Skid Plates Pair	N/A
2	18968	5/8"-18 x 4.0" Yellow Zinc Finish Hex Cap Screw	Grade 8
4	33819	5/8" x 1.312" OD Yellow Zinc Finish Flat Washer	Grade 8
2	37312	5/8"-18 Zinc Finish Steel Top Lock Nut	Grade C
2	15103	3/8"-16 x 0.75" Yellow Zinc Finish Hex Cap Screw	Grade 8
2	33815	3/8" x 0.812" OD Yellow Zinc Finish Flat Washer	Thru-Hardened
2	36406	3/8"-16 Yellow Zinc Finish Hex Nut	Grade 8

## Product Notes and Features:

- Designed with a  $\frac{1}{4}$ " thick steel construction
- Formed and bent to mount around the OEM lower control arm mount, meaning no interference with the control arm bushing itself
- Upgraded 5/8" hardware included to replace the undersized, OEM 16mm bolt
- Additional 3/8" mounting hardware included
- Clearance gap for control arms at full articulation
- Provides a solid, sturdy, and protective barrier between obstacles and your adjustable rear lower control arms
- **Minor drilling may be required to fasten the provided 3/8"-16 bolts to certain vehicle models and years.**

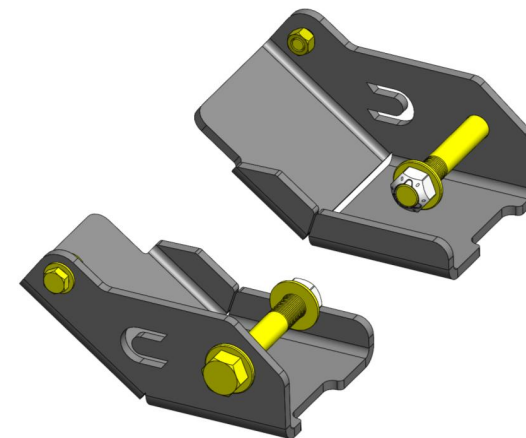

**NOTE:** Reaming out the rear lower control arm bushing may be required depending on your aftermarket control arm manufacturer. COR has tested and confirmed fitment (no reaming required) on factory lower control arms, as well as COR lower control arms.

# DISCLAIMER

## WARNING:

Suspension systems and their components are designed to enhance your vehicle's off-road performance. This may cause your vehicle to handle differently, on and off-road. Always wear your seatbelt and take extra care when driving a modified vehicle. Failure to do so can result in loss of control which may result in a rollover causing serious injury, or even death to the driver and/or passengers of the vehicle. Regular maintenance and consistent inspections are required to keep your modified vehicle safe and functioning properly. These suspension systems and any components should be installed by certified technicians only. Attempts to install these products without proper knowledge can lead to poor performance, or possible failure, which may jeopardize the safety of the vehicle and its passengers. The installer is responsible for proper installation ensuring a safe and properly functioning vehicle. Take extra care when operating a modified vehicle and thoroughly inspect your vehicle before and after every off-road use.

Read the instruction set in its entirety before attempting the installation.

## NOTE:

This product may require general welding, fabrication, and automotive mechanic skills. Welding should only be done by a competent welder. Clayton Off Road implies no guarantees or warranties and is not liable for improper installation. Some grinding and fitment may be required when installing this product. Every vehicle varies slightly, and some fabrication and/or modification may be required.

## ATTENTION:

It is the customer's responsibility to thoroughly inspect all received parts to ensure they are assembled correctly and fully welded. Please carefully examine all weld seams and verify that bolt-through holes are properly aligned. Some Clayton Off Road products are permanent, non-removable, weld-on solutions. **If a defect or issue is found after installation, especially with permanent weld-on components, it may be difficult or impossible to correct.** Inspecting the part(s) received beforehand helps prevent unnecessary and avoidable complications.

## ATTENTION: TORQUE SPECIFICATION

When working on any vehicle, it is good practice to torque suspension/weight-bearing components while the vehicle is resting under its load. This instruction set, as well as any other Clayton Off Road instruction set, assumes the installer will tighten any suspension-related components properly, to the recommended torque specification, when the vehicle is resting safely under its own weight.

# INSTALLATION INSTRUCTIONS

\*\*\*Take this product to a licensed professional if you are hesitant about the installation process!\*\*\*

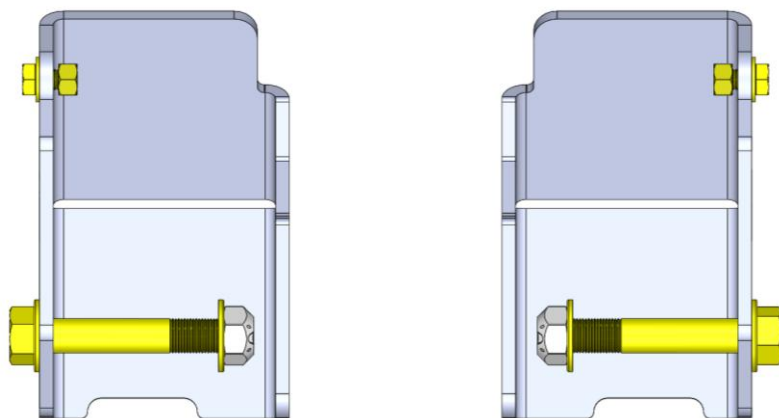

## TOOLS REQUIRED FOR THIS INSTALLATION:

- Impact drill
- Needle-nose pliers
- Metric and SAE socket sets
  - 21, 24mm box wrenches/sockets
  - 15/16, 9/16" box wrenches/sockets
- Tape or electrical tape
- Torque wrench
- 3/8" drill bit and drill (**depending on vehicle year/model**)

**NOTE:** This product can be installed on a vehicle lift or on the ground. However, an adjustable / locking jack stand is required.

# INSTALLATION INSTRUCTIONS

1. Position the vehicle on flat ground or a lift. Position the jack stand at the rear right axle tube. Adjust the jack stand until it puts slight pressure on the tube. This will support the axle and allow the control arm to be easily removed/reinstalled.



Figure 1: Vehicle positioned on a four-post lift with supporting axle jack stand

# INSTALLATION INSTRUCTIONS

2. Remove the right rear lower control arm bolt at the frame-end using a 24mm and 21mm socket/wrench.

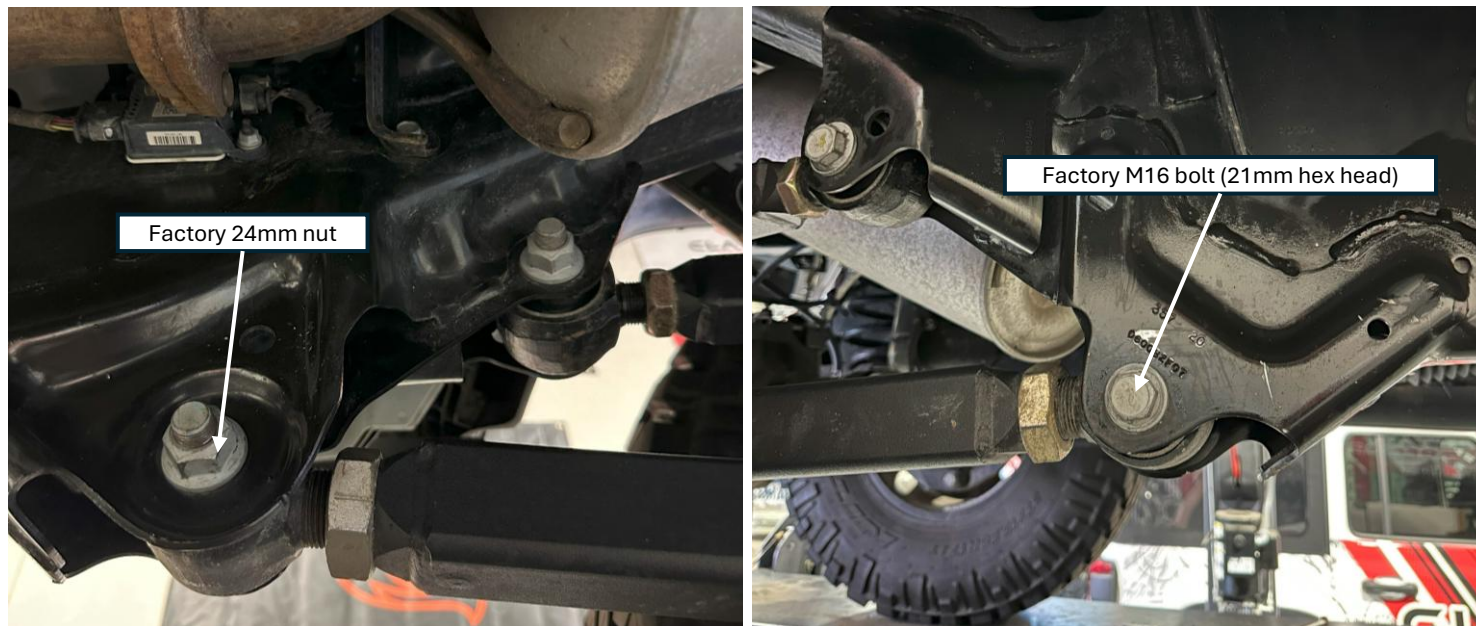

Figure 2: Right rear lower control arm bolt (frame-end) to be removed

**TIP:** This lower control arm bolt will be very tight, as a high torque specification is required to achieve the necessary clamp force on the bushing. Use an impact driver in the removal of this bolt and nut.

You may also want to loosen the axle-end control arm bolt, but **do not remove this bolt.**

# INSTALLATION INSTRUCTIONS

3. Depending on the year and model of your vehicle, you may need to drill out the hole location marked below.

If this is the case for your installation, install the control arm bolt **first**, along with the skid plate bracket, with the control arm already in place. Tighten the control arm bolt temporarily to locate where to begin drilling. Drill **the OEM bracket to fit the new skid plate.** Stop drilling before you hit the vehicle's frame.

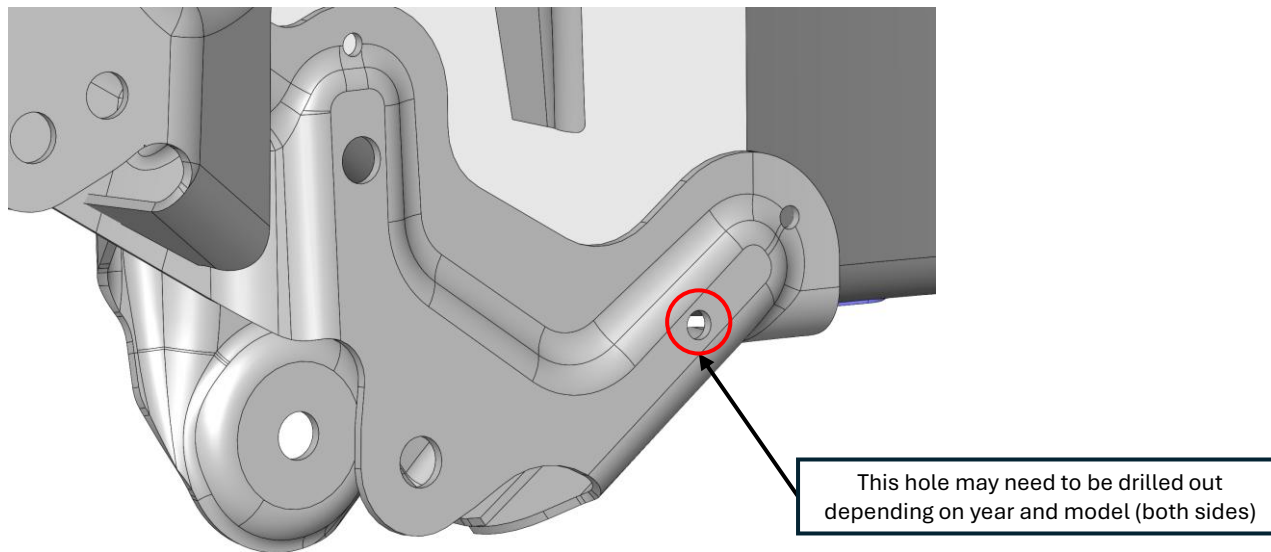

Figure 3: OEM rear lower control arm bracket (JT)

# INSTALLATION INSTRUCTIONS

4. Swing the control arm down and out of the mount, for now. **Use electrical tape or a small strip of duct tape** and stick one of the provided 3/8" nuts to it. As seen below, reach into the control arm mount from the inside and align the nut with the open hole from the outside of the frame bracket.

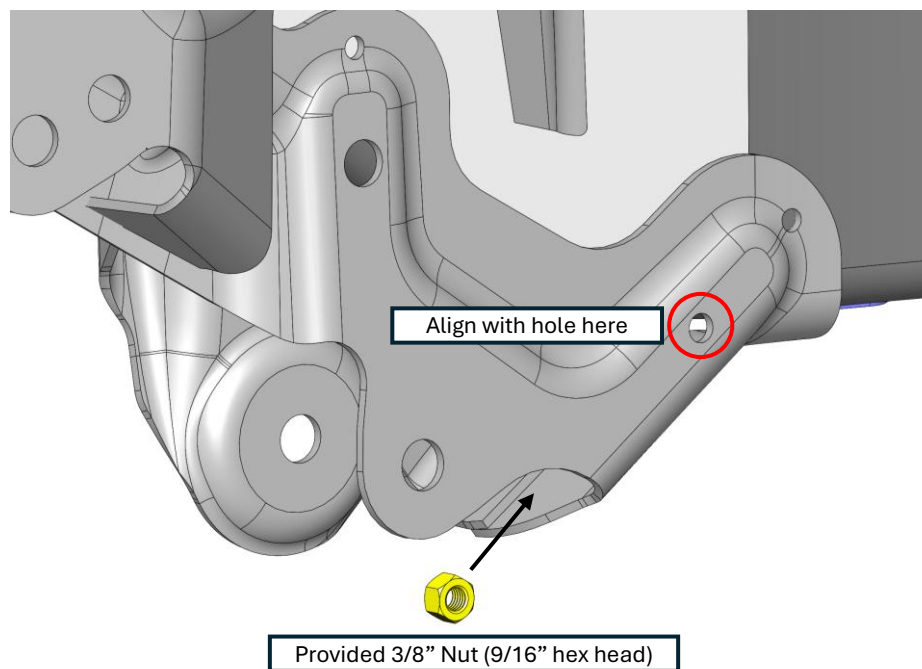

Figure 4: Locating 3/8" nut **inside** the control arm bracket

**NOTE:** It may be difficult to locate the nut inside the bracket when the skid plate is in place due to minimal clearance. Therefore, it is highly recommended to temporarily fix the nut on the inside of the bracket with tape.

# INSTALLATION INSTRUCTIONS

5. Swing the control arm back up into the mount and align the arm bushing with the OEM bracket. Bring the control arm skid plate up and into position, with the mounting face of the new bracket flat up against the control arm bracket.

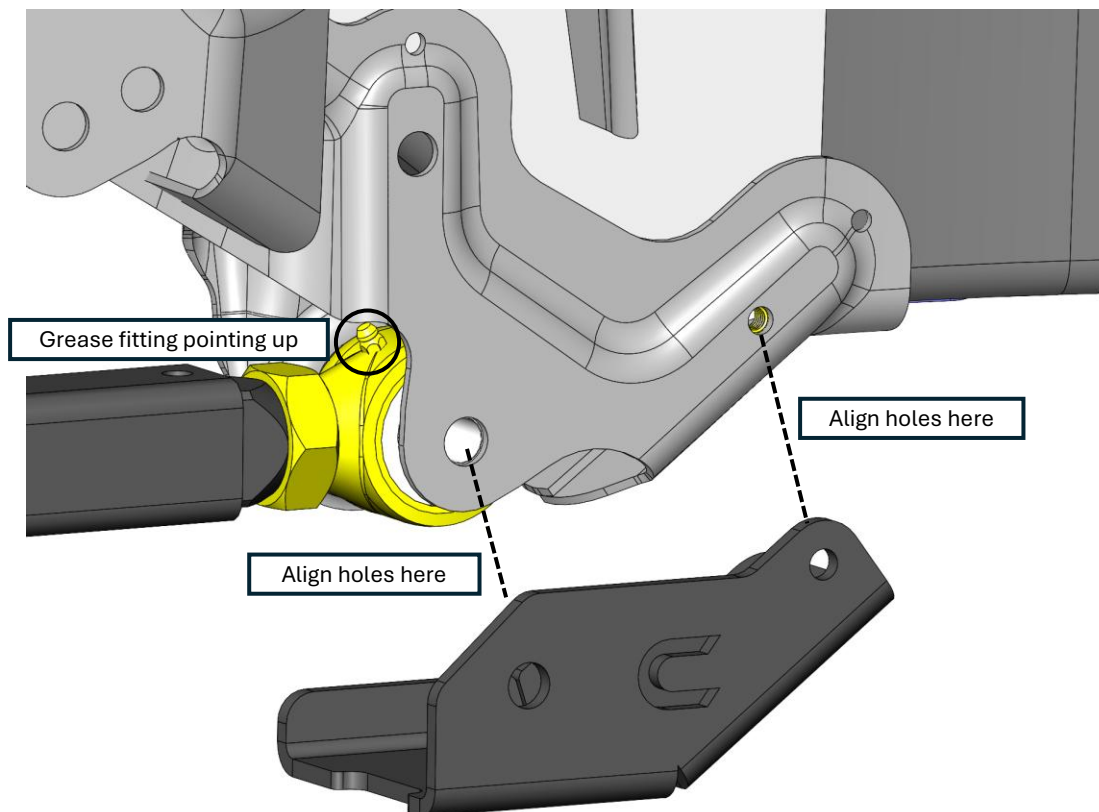

Figure 5: Locating the right bracket into position

**NOTE:** If you have our PREMIUM Series Control Arms, ensure that the grease fitting is pointing up (see above).

# INSTALLATION INSTRUCTIONS

6. Carefully begin threading the provided 3/8"-16 bolt through to the "taped" nut, with the washer on the outside of the bracket.

Once a few threads have been caught, remove the tape (with needle-nose pliers) and feed a 9/16" box wrench in through the inside of the mount to hold the nut. **Tighten the nut with the bracket hole still aligned with the control arm hole.** Then, feed the control arm bolt through the skid plate, bracket, and control arm bushing with the provided washer. See the two figures below.

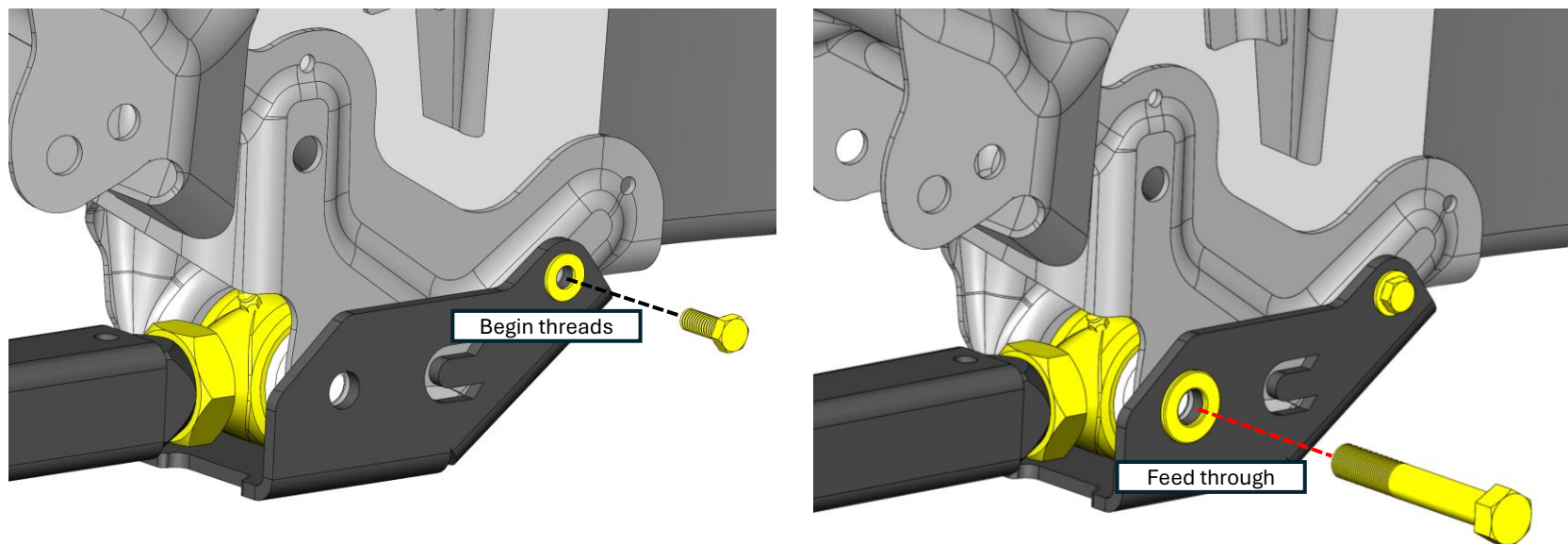

Figure 6: Mounting bolts and hardware

**TIP:** A lock nut/washer is **not** provided with the 3/8" bolt because of minimal clearance inside the bracket. If you are concerned with the hardware coming loose, **apply a small drop of blue thread locker to the threads of the 3/8" bolt, then tighten.**

# INSTALLATION INSTRUCTIONS

7. Install the provided 5/8" washer and lock nut on the opposite side of the control arm mount. **Leave the nut loose at this time; do not tighten or torque the nut.**

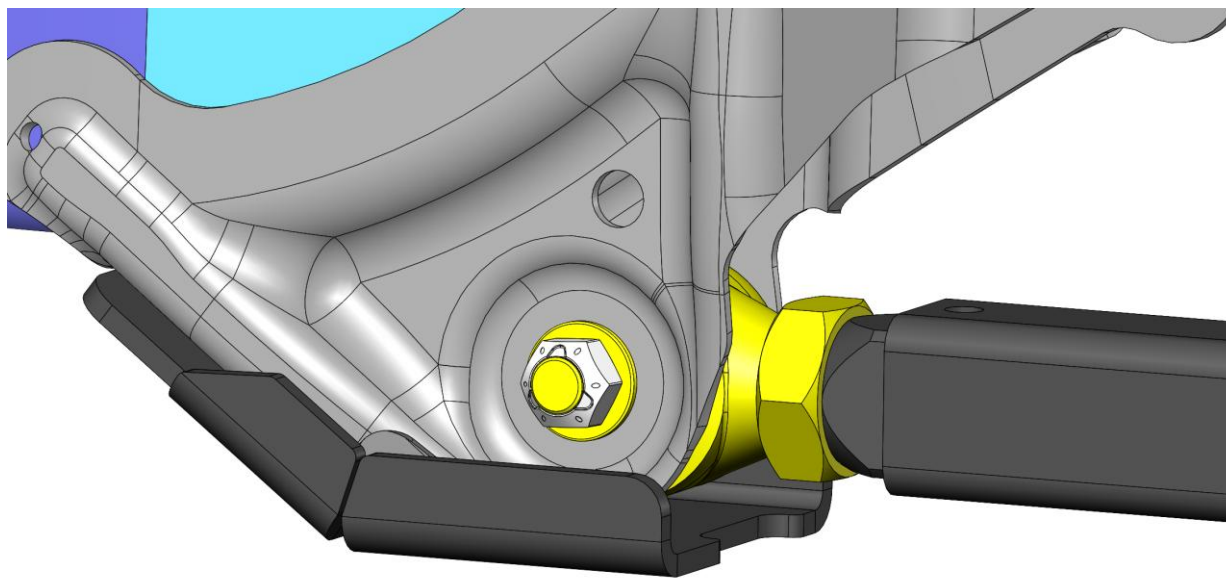

Figure 7: Back of skid plate and hardware

**TIP:** If the control arm bushing seems off and you cannot feed the bolt through, simply raise or lower the jack stand slightly, hold the control arm up to the hole, and align the bushing with the thru-hole.

# INSTALLATION INSTRUCTIONS

- Repeat Steps 2 – 6 on the left side. When both skid plates are loosely installed with hardware, remove the supporting axle stands and lower the vehicle to the ground if it isn't already.

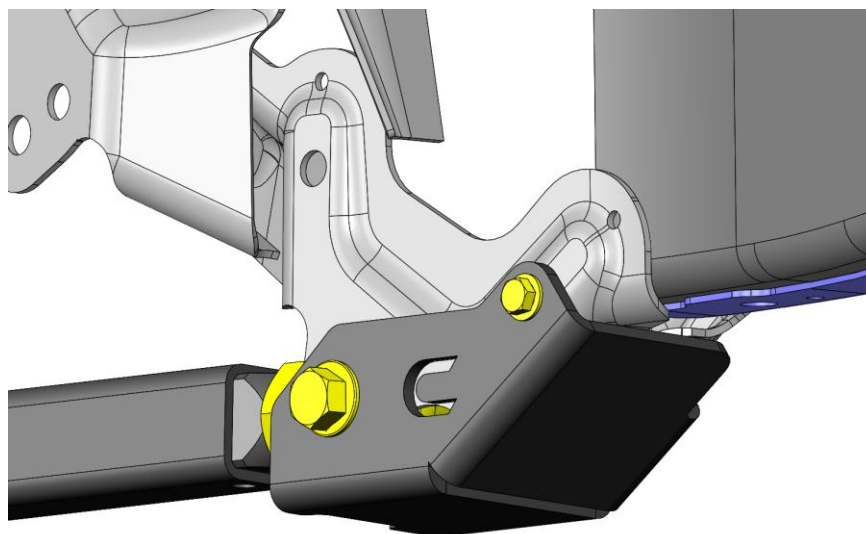

Figure 8: Driver-side bracket installed

**NOTE:** Do not forget to move the jack stand to the rear left axle tube for the left skid plate installation

# INSTALLATION INSTRUCTIONS

9. It is now time to torque the new hardware to specification. **With the vehicle resting on flat ground and under its weight,** torque the lower control arm bolts at the frame to **180 ft-lbs.** The new hardware wrench sizes are listed below:

Frame-end control arm bolt:

15/16" socket, 15/16" wrench



Figure 9: Prototype (unpainted) skid plate torqued to specification

# INSTALLATION INSTRUCTIONS

10. The installation is now complete. Be sure to re-torque all replaced hardware after 500 miles of driving. Inspect any/all skid plates after an impact for damage.

