

S7219

2020-2022 MUSTANG GT500, 5.2L,
RESONATOR BYPASS

MBRP®

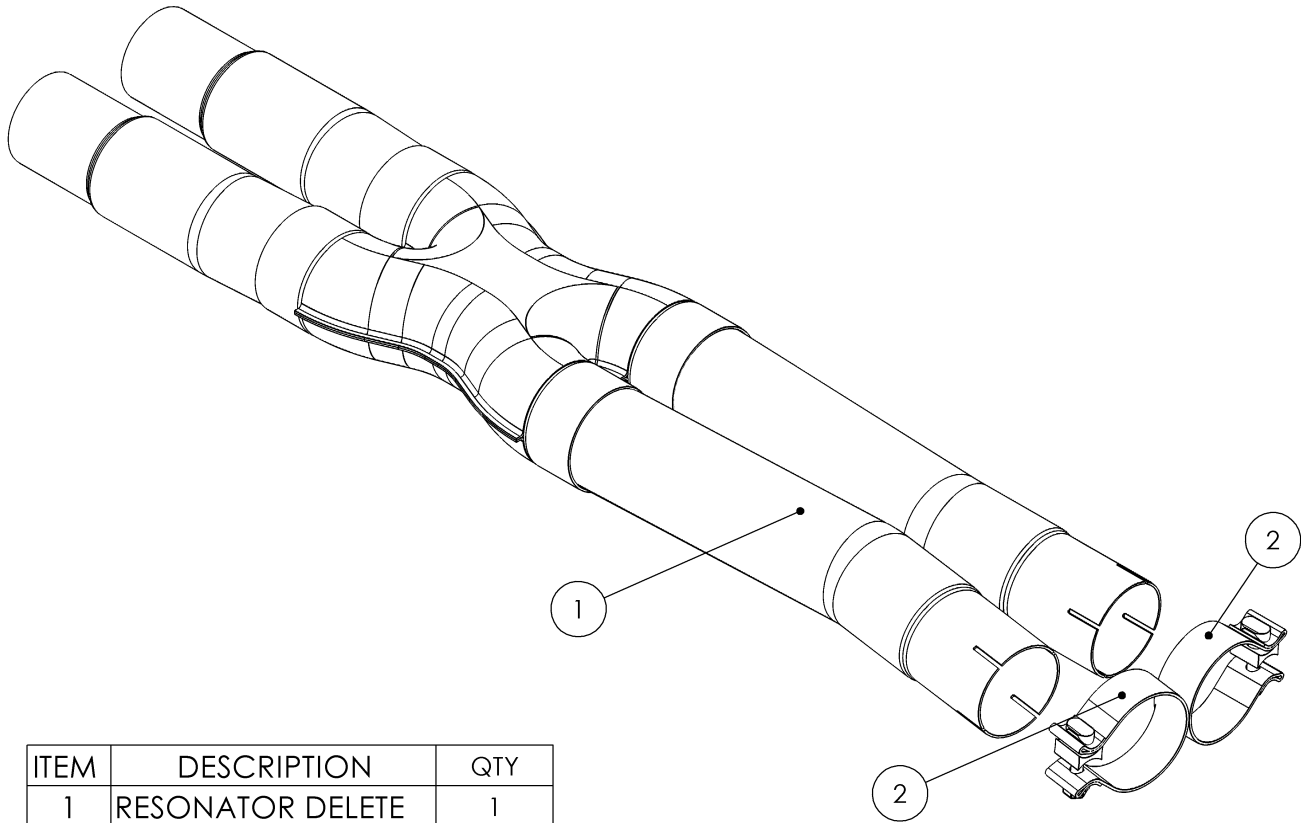

ITEM	DESCRIPTION	QTY
1	RESONATOR DELETE	1
2	2.75"CLAMP	2

Refer to this LOT NUMBER when contacting customer service: _____

PLEASE READ BEFORE STARTING INSTALLATION

While MBRP has made every effort to ensure that all components of this system are of superior quality and properly packaged, it is the installer's responsibility to ensure the following before removal of the factory exhaust:

- that ALL components shown above are present.
- that ALL mating components fit together.
- that there are no damaged components.
- that the system you have purchased is appropriate for your vehicle year, model and configuration.
- that the system will not interfere with any modifications previously installed or planned.
- that you have read and understand these instructions.

If you have any questions or are uncertain about any aspect of the installation of this system to your vehicle please contact your dealer before commencing installation.

MBRP

Installation of MBRP Performance Exhaust

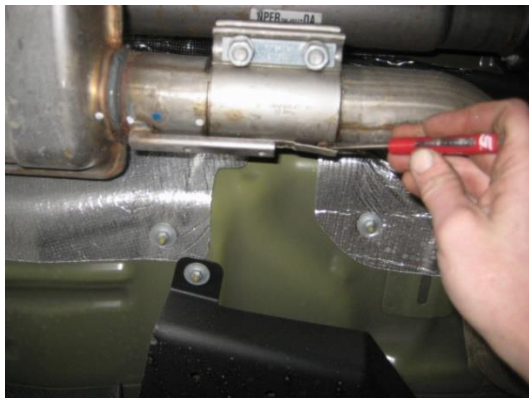

Figure 1



Figure 2



Figure 3



Figure 4

1. Loosen both OEM clamps and disconnect the cat back section of the exhaust from both front pipes. Allow the inlet of the cat back to hang down.

Refer to Figure 1.

2. Position the **Resonator Delete Assembly** underneath the OEM cat back being sure the inlets are aligned flush with each other. Note that the outlets of **Resonator Delete Assembly** should be pointing down slightly, NOT pointing up. Transfer marks from the end of the **Resonator Delete Assembly** to the OEM Catback.

Refer to Figure 2.

3. Measure 2.5" forward toward the front of the car from the marks made in step 2 and scribe a cut line on the OEM pipes. Using a sawsall or similar tool, cut and deburr the OEM pipes.

Refer to Figure 3.

4. Install a **2.75" Clamp** onto each outlet of the **Resonator Delete Assembly** before connecting it to the section of cat back exhaust remaining on the vehicle.

5. Reusing the original clamps, connect the **Resonator Delete Assembly** to the front pipes. Ensure the assembly is installed level as viewed from the rear and tighten all clamps.

Refer to Figure 4.

6. Align the edge of each band clamp with the edge of the joint it is connecting. Tighten all hardware and clamps, starting at the front and working rearward to secure the system. Check along the full length of the exhaust system to ensure there is adequate clearance for fuel lines, vent lines, brake lines, frame, bodywork, suspension, and any wiring, etc. If there is any interference detected, relocate, or adjust to provide adequate clearance. Ensure all clamp connections are secure and components are unable to rotate or slide. Band clamps require approximately 45 lb-ft (60 N-m) of torque. Verify clearances, system security and band clamp torque after 30-60 miles (50-100 km) of driving.

Congratulations! You are ready to begin experiencing the improved performance and driving pleasure of your **MBRP** performance exhaust system. We know you will enjoy your purchase.