

MBRP®

AT-9535PT

SLIP-ON MUFFLER ASSEMBLY, 5"

2018-2019 POLARIS RANGER XP 1000, EXCLUDING NORTHSTAR, BACK COUNTRY, AND HIGH LIFTER
2019 POLARIS RANGER CREW XP 1000, EXCLUDING NORTHSTAR, BACK COUNTRY, AND HIGH LIFTER
2020 POLARIS RANGER / RANGER CREW 1000, EXCLUDING NORTHSTAR AND BACKCOUNTRY
2020-UP POLARIS RANGER / RANGER CREW XP 1000, EXCL. NORTHSTAR, HIGH LIFTER, AND WATERFOWL

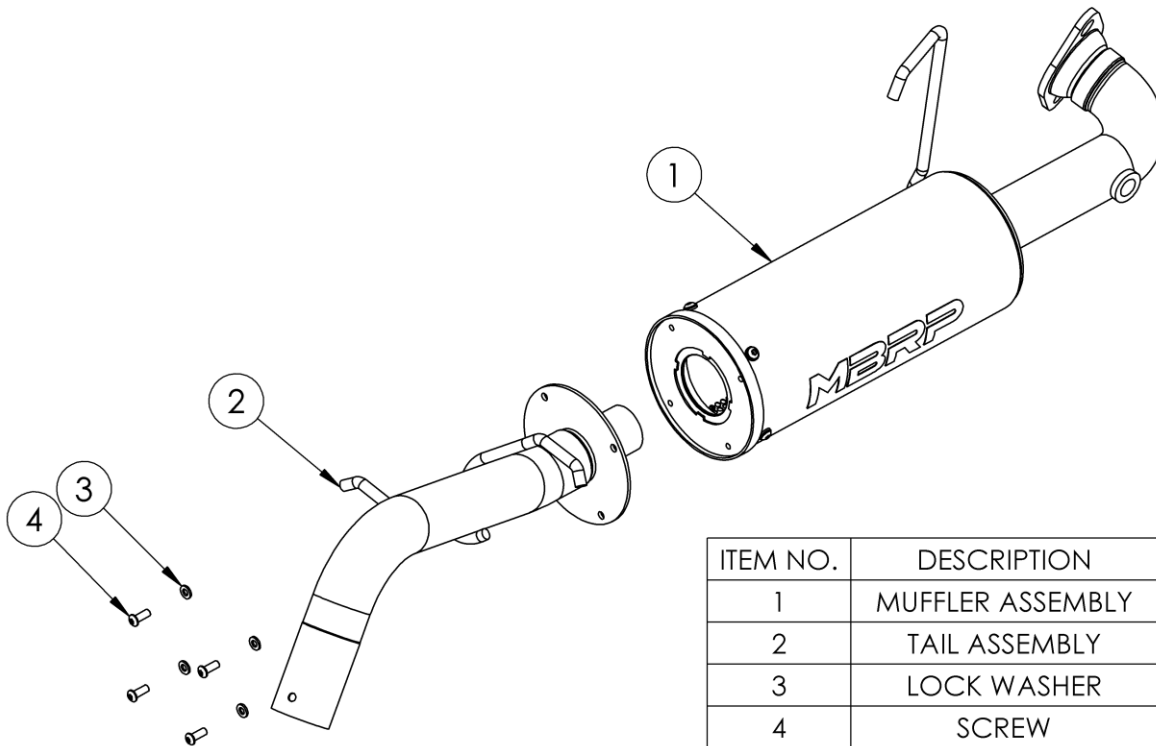

ITEM NO.	DESCRIPTION	QTY.
1	MUFFLER ASSEMBLY	1
2	TAIL ASSEMBLY	1
3	LOCK WASHER	4
4	SCREW	4

Refer to this LOT NUMBER when contacting customer service: _____

PLEASE READ BEFORE STARTING INSTALLATION

While MBRP has made every effort to ensure that all components of this system are of superior quality and properly packaged, it is the installer's responsibility to ensure the following before removal of the factory exhaust:

- that ALL components shown above are present.
- that ALL mating components fit together.
- that there are no damaged components.
- that the system you have purchased is appropriate for your vehicle year, model and configuration.
- that the system will not interfere with any modifications previously installed or planned.
- that you have read and understand these instructions.

If you have any questions or are uncertain about any aspect of the installation of this system to your vehicle please contact your dealer before commencing installation.

MBRP

Removal of Stock Exhaust:

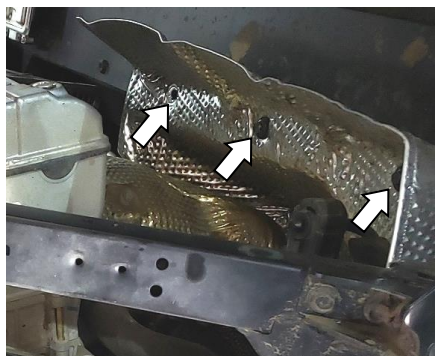

Figure 1



Figure 2



Figure 3



Figure 4

1. Apply penetrating lubricant liberally to all exhaust fasteners, hangers, and rubber isolators.
2. Lift the dump box and remove the clevis pin from the shock to allow the box to pivot fully open.
3. Remove the two (2) bolts securing the muffer inlet flange to the head pipe. Keep the bolts and springs as they will be reused with the new system.
4. Loosen or remove the five (5) screws securing the front heat shield to the vehicle (**Refer to Figure 1**). This will allow it to shift enough to let the exhaust sensor slide out of the hole as the exhaust is removed.
5. From underneath the vehicle, reach up through the frame and behind the front heat shield to disconnect the the exhaust sensor wiring.
6. Remove the three (3) muffer hangers from the vehicle isolators, then remove the exhaust. **Refer to Figure 2**.
7. Ensure that the gasket is not damaged, then leave it on the head pipe for reuse.
8. Remove the exhaust sensor from the muffer inlet. Note that the heat shield must be removed first. Set the exhaust sensor aside to be reinstalled in the new **Muffer Assembly**.
9. Remove the screw and nut that secure the spark arrester, keeping them for reuse. Remove the spark arrester to reuse it in the new **Muffer Assembly**.

Installation of MBRP Exhaust:

1. Place the spark arrester into the new **Tail Assembly**, ensuring that the screw hole is aligned with the hole at the end of the outlet. Use the nut and screw removed from the stock assembly to secure the spark arrester.
2. Assemble the **Tail Assembly** to the **Muffer Assembly** using the **Lock Washers** and **Screws**.
3. Place the assembled exhaust into position and slide the hangers (3) into the isolator mounts. **Refer to Figure 3**.
4. Reinstall the inlet bolts and springs onto the head pipe. **Refer to Figure 4**.
5. Feed the exhaust sensor wire through the front heat shield and then install the sensor into the muffer inlet pipe. **Refer to Figure 4**.
6. Reconnect the sensor wire, then reinstall the screws to secure the front heat shield.
7. Finally, reinstall the clevis pin to connect the shock to the dump box.

In order to maintain optimal performance, the spark arrester screen should be cleaned after every 30-35 hours of use.

Congratulations! You are ready to begin experiencing the improved performance and driving excitement of your **MBRP** Ltd. Exhaust upgrade. We know you will enjoy your purchase.