

AT-9524PT

DUAL SLIP-ON MUFFLER ASSEMBLY
2020-UP POLARIS RZR PRO XP

MBRP

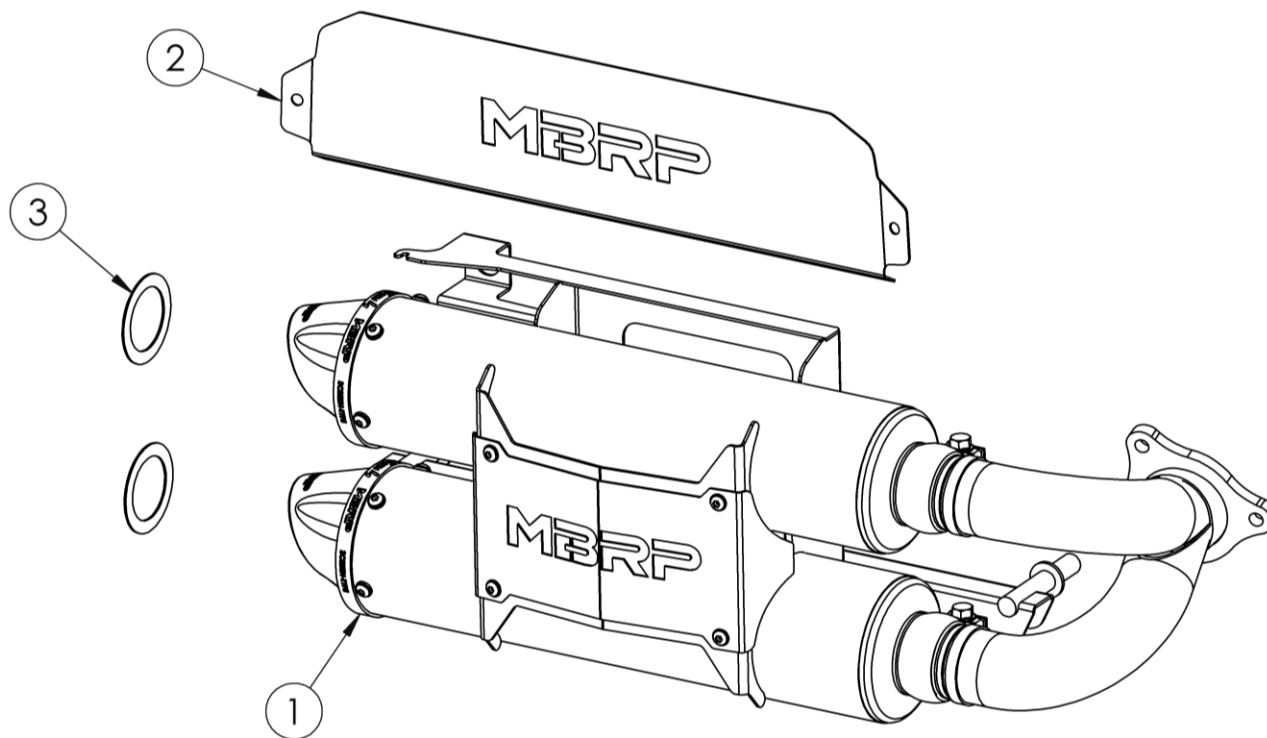

ITEM NO.	DESCRIPTION	QTY.
1	MUFFLER ASSEMBLY	1
2	REAR PLATE	1
3	RING INSERT	2

PLEASE READ BEFORE STARTING INSTALLATION

While MBRP Ltd. has made every effort to ensure that all components of this system are of superior quality and properly packaged, it is the installer's responsibility to ensure the following before removal of the factory exhaust:

- that ALL components shown above are present.
- that ALL mating components fit together.
- that there are no damaged components.
- that the system you have purchased is appropriate for your vehicle year, model and configuration.
- that the system will not interfere with any modifications previously installed or planned.
- that you have read and understand these instructions.

If you have any questions or are uncertain about any aspect of the installation of this system to your vehicle please contact your dealer before commencing installation.

MBRP

Removal of Stock Exhaust:

1. Remove the rear panel covering the muffler. Do not discard the fasteners. **Refer to Figure 1.**
2. Remove the three (3) nuts securing the muffler inlet to the exhaust pipe. Do not discard them. Leave the gasket on the vehicle exhaust pipe.
3. Remove the upper and lower springs securing the muffler to the vehicle. Do not discard the springs.
4. Remove the muffler by sliding the hangers out of the rubber isolators.
5. Remove the two (2) lower brackets that held the bottom of the panel in place. **Refer to Figure 2.**



Figure 1

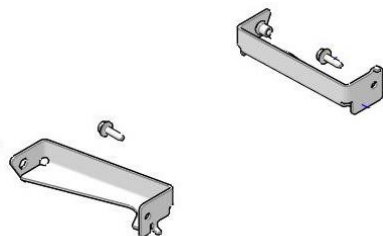

Figure 2

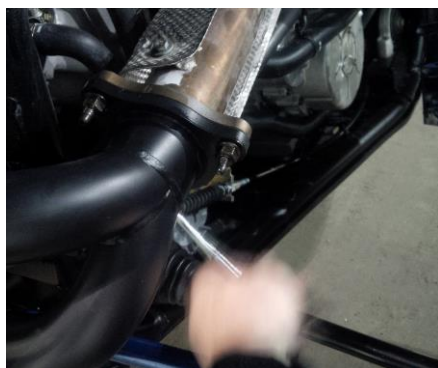

Figure 3



Figure 4



Figure 5

Installation of MBRP Exhaust:

1. Slide the hanger rods into the rubber isolators on the vehicle and mate the **Muffler Assembly** inlet pipe to the end of the exhaust pipe. **Refer to Figure 3.**
*If necessary, the position of the muffler support bracket can be adjusted by removing the logo plate and loosening the two (2) 8mm bolts holding the brackets together.
2. Secure the **Muffler Assembly** by attaching the previously removed spring at the top location. **Refer to Figure 4.**
*If necessary, the inlet y-pipe can be adjusted by loosening the muffler inlet clamps.
3. Re-install the lower spring to the tab on the mounting bracket. **Refer to Figure 5.**
4. Secure the inlet using the previously removed stock nuts.
5. Install the **Rear Plate** where the top of the rear panel used to be. Reuse the screws that were previously removed from the mounting holes.

Note:

The mufflers come with a quiet insert pre-installed to limit sound levels to 96dB at half-throttle. If increased flow is desired, use the **Ring Inserts** as follows:

- 1) remove the four (4) screws securing the outlet tips to the mufflers
- 2) remove the spark arrestor and quiet insert
- 3) replace the quiet insert with the supplied **Ring Insert** and replace the spark arrestor
- 4) reinstall the outlet tips

It is recommended that the muffler screws be retightened after the first ride and checked periodically thereafter, tightening if necessary.



Congratulations! You are ready to begin experiencing the improved performance and driving excitement of your MBRP Exhaust upgrade. We know you will enjoy your purchase.



Figure 1



Figure 2



Figure 3



Figure 4

Spark Arrestor Maintenance

In order to maintain optimal performance, the spark arrestor screen should be cleaned after every 30-35 hours of use.

Clean-out Instructions:

Make sure the vehicle is cool before completing the clean-out procedure.

1. Using a 4mm hex key, remove the 4 screws securing the outlet cap or tip. **(Figure 1)**
2. Remove the outlet cap to expose the spark arrestor screen insert. **(Figure 2)**
3. Remove the screen insert. **(Figure 3)**
4. Using a wire brush, thoroughly brush the screen to remove residue. **(Figure 4)**
5. Replace the screen and cap.
6. Tighten the screws to 60 in-lbs (6.8 Nm).